

Department of Mechanical Engineering and Mechanics

Drexel University College of Engineering

The following item is made available as a courtesy to scholars by the author(s) and Drexel University Library and may contain materials and content, including computer code and tags, artwork, text, graphics, images, and illustrations (Material) which may be protected by copyright law. Unless otherwise noted, the Material is made available for non profit and educational purposes, such as research, teaching and private study. For these limited purposes, you may reproduce (print, download or make copies) the Material without prior permission. All copies must include any copyright notice originally included with the Material. **You must seek permission from the authors or copyright owners for all uses that are not allowed by fair use and other provisions of the U.S. Copyright Law.** The responsibility for making an independent legal assessment and securing any necessary permission rests with persons desiring to reproduce or use the Material.

Please direct questions to archives@drexel.edu

Drexel University Libraries
www.library.drexel.edu



<http://www.drexel.edu/>

A Competition to Identify Key Challenges for Unmanned Aerial Robots in Near-Earth Environments

William E. Green, Keith W. Sevcik and Paul Y. Oh*
weg22@drexel.edu, kws23@drexel.edu, paul.yu.oh@drexel.edu

Abstract

Tasks like bomb-detection, search-and-rescue, and reconnaissance in near-Earth environments are time, cost and labor intensive. Aerial robots could assist in such missions and offset the demand in resources and personnel. However, flying in environments rich with obstacles presents many more challenges which have yet to be identified. For example, telephone wire is one obstacle that is known to be hard to detect in mid-flight. This paper describes a safe and easy to fly platform in conjunction with an aerial robot competition to highlight key challenges when flying in near-Earth environments.

1 Introduction

Homeland security and search-and-rescue missions often require large, diverse task forces. Ground-based robots have shown much potential in offsetting this demand in resources and personnel [2] [8]. However, flying has certain advantages over crawling. For example, gathering intelligence around a mountain or in a cave could be done quickly and efficiently with an aerial robot. Also, oftentimes different perspectives (e.g. "bird's-eye" view or a view through a higher-story window) can be more effective. As a result, heightened interest has evolved in small unmanned aerial vehicles (UAVs) that can fly in and around buildings, at low altitudes over rugged terrain, and under forest canopies. Conventional UAVs rely heavily on global positioning systems (GPS) and inertial measurement units (IMUs) for navigational waypoints and localization, respectively. However, GPS signals are faint when line-of-sight to the satellites is occluded. Furthermore, UAVs capable of maneuver-

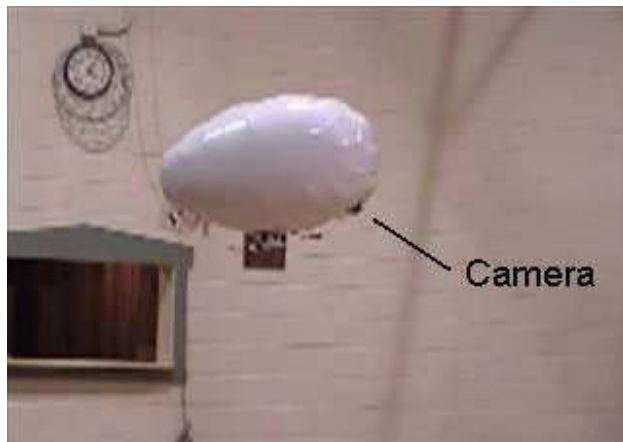

Figure 1: A 30 inch diameter blimp carrying a 14 gram mini wireless camera can provide surveillance images of urban structures.

ing in *near-Earth* environments must be small and capable of flying at extremely slow speeds [5]. Therefore, the payload capacity is significantly reduced and carrying bulky sensors, like IMUs, is not feasible. The net effect is that small, lightweight (i.e. less than 100 grams) alternative approaches are required for the development of sensor suites for aerial vehicles flying in near-Earth environments.

Small commercial UAVs, capable of flying in near-Earth environments, are currently being developed by Honeywell, BAE Systems and Piasecki Aircraft. However, they are not yet available as research platforms. Nonetheless, sensor suites enabling autonomous navigation can be developed in parallel. A blimp is a simple and safe test bed suitable for sensor suite evaluation (see Figure 1). A 30 inch diameter blimp can fit through standard doorways and carry a payload of 60 grams. This is enough to carry a miniature wireless camera, or stereo pair, as well as ranging sensors (IR, SONAR, etc.). With payloads under a 100 grams, optimizing the number and types of onboard sensors is critical. Optimization requires the iden-

*The U.S. Army Medical Research Acquisition Activity, 820 Chandler Street, Fort Detrick, MD 21702-5014 is the awarding and administering acquisition office. This investigation was funded under a U.S. Army Medical Research Acquisition Activity; Cooperative Agreement W81XWH 04-1-0419. The content of the information herein does not necessarily reflect the position or the policy of the U.S. Government or the U.S. Army and no official endorsement should be inferred

tification of environmental obstacles and challenges. Towards this, Drexel University organized the first indoor aerial robot competition (hosted by Swarthmore College) in May 2005. The inaugural competition was structured to highlight and identify key challenges and the potential for aerial robots in urban reconnaissance and search-and-rescue missions.

There are few competitions which currently exist for aerial robots. The university of Florida and Arizona State University host an annual micro-air-vehicle (MAV) competition focusing on platform design. The main objective is to design the smallest possible platform capable of identifying a target 600 *meters* away with an onboard camera. Similarly, the Association for Unmanned Vehicles International (AUVSI) hosts an annual competition at the Army’s Urban Operations site in Fort Benning. While the AUVSI competition focuses more on autonomous flight, both competitions fail to look at navigating unmanned vehicles in the absence of GPS; a critical aspect of flight in near-Earth environments.

This paper illustrates how a blimp can be used as a test bed for an aerial robot competition to identify near-Earth challenges. Section 2 discusses a blimp’s platform characteristics and dynamics. Section 3 demonstrates the use of several sensors, namely optic flow and computer vision. Section 4 discusses the competition layout and tasks to be exercised such as collision avoidance, gust stabilization and target identification. Finally, section 5 concludes by summarizing.

2 Aerial Platform

Off-the-shelf radio-controlled (RC) aircraft serve as efficient templates for near-Earth aerial platforms. They can easily be scaled down and modified to carry additional payloads, fly at slower speeds or increase endurance (see Figure 2). However, platform selection is not as straightforward because tradeoffs for each vehicle exist. For example, while rotorcraft possess the ability to hover, they are difficult to control [7] [9]. Fixed-wing aircraft can fly slowly and are easily maneuverable, but have limited payload capacities and cannot hover [11] [10]. Lighter-than-air platforms can hover and carry sufficient payloads, but their large inertia prevents rapid maneuvering. However, the maneuverability constraint of a blimp is offset by the natural tendency to oppose any rotation about the roll and pitch axes. This is a result of an overall low center-of-gravity (i.e. causes it to be bottom-heavy)

induced by the weight of the gondola. This greatly simplifies the control effort of autonomous flight and is therefore, the platform used in the competition.

2.1 Lighter-Than-Air Vehicles

Helium gas¹ provides the lift force for blimps rather than wings and electric motors. Therefore, they can remain airborne for hours and days versus minutes for rotary and fixed-wing aircraft. The blimp suggested for the competition has a volume of 4.5 *ft*³ enabling it to carry a payload of 60 *grams* in addition to the gondola and electronics. Figure 3 depicts a free body diagram of the blimp and gondola. It has three bi-directional motors; two are attached to the gondola and one at the rear. The two front motors are mixed (i.e. rotate in unison) and allow the blimp to move in the forward and reverse directions (along the *x*-axis). The front motors are fixed to a common shaft which can be rotated by an RC servo in order to control the blimp’s altitude. The angle the motors are rotated relative to the *x*-axis is denoted as α . The blimp’s yawing motion (rotation about the *z*-axis) is controlled by the rear motor.

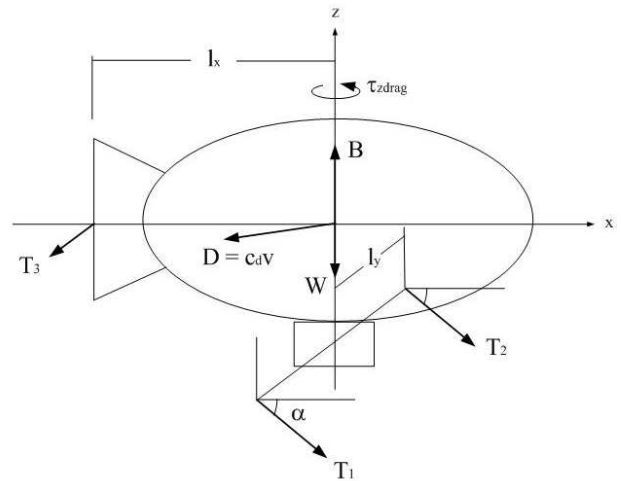

Figure 3: Blimp force diagram

The four forces of flight acting on the blimp are buoyancy *B*, weight *W*, thrust *T* and drag *D*. The blimp is assumed to be in mid-flight. The *z*-axis (vertical), *x*-axis (parallel to the ground) and forces of buoyancy, drag and weight intersect at the center of buoyancy. The thrust forces act at the locations of the propellers and the drag force is in the direction opposite of mo-

¹Helium has a lifting capacity of 0.064 *lbs/ft*³ (1.02 *kg/m*³)



Figure 2: With a 18 *inch* wingspan, our fixed-wing aerial platform (left) can fly as slow as 2 *m/s* and carry a payload of 20 *grams*. Rotorcraft, such as helicopters (middle) and ducted fan engines (right), are difficult to fly.

tion. The equations of motion for a blimp are statements of Newton's second law, $F=ma$ [14]

$$\begin{aligned}
 m_x a_x &= (T_1 + T_2) \cos \alpha - D_x \\
 m_z a_z &= D_z + (T_1 + T_2) \sin \alpha \\
 J_z \dot{\omega}_z &= (T_1 - T_2) l_y \cos \alpha + T_3 l_x + \tau_{z \text{ drag}}
 \end{aligned}$$

2.2 PC-to-RC

Computer control of the blimp using a ground based PC was achieved via a PC-to-RC circuit [13]. As depicted in Figure 4, the PC-to-RC circuit provides a bridge between the control software implemented on the PC and a conventional RC transmitter. The microcontroller (see Figure 5) transforms digital commands sent from the PC into pulse width modulated (PWM) signals which are sent to the buddy port of the RC transmitter. The buddy port of the transmitter is typically used to allow an expert RC pilot to take over the controls of an amateur. In our case, the buddy port closes the circuit and allows the PC to take control of the system.

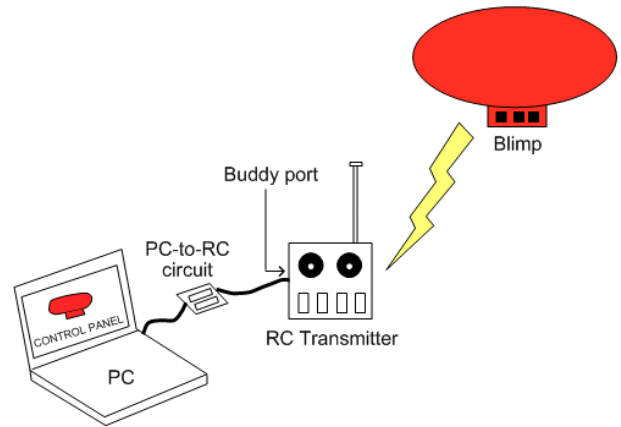

Figure 4: A PC-to-RC circuit converts digital commands to RC signals. Commands are then sent wirelessly to the blimp through a RC transmitter.

This system can be used as an alternative means for navigating unmanned aircraft where line-of-sight to GPS satellites is occluded. However to be most useful, this control system must be integrated with sensors to allow the accurate perception of the flying environment.

3 Sensors

Intelligence obtained from sensors allows the robot's control system to make sophisticated decisions. In addition to traditional sensors such as sonar, infrared (IR) and vision, biomimetic sensors can be constructed as lightweight packages. Integrating such hardware can produce an efficient sensor suite for near-Earth environments.

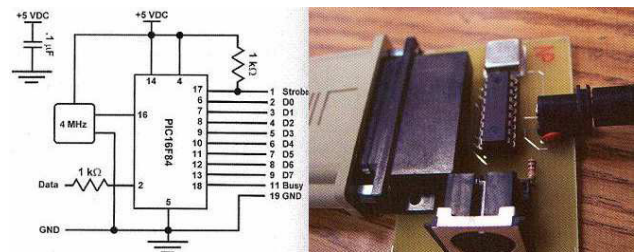

Figure 5: PC-to-RC schematic juxtaposed with actual circuit.

3.1 Biomimetic Sensing

Flying insects perform many complex tasks (e.g. collision avoidance, speed control, landing, etc.) in cluttered environments without the use of GPS or IMUs. They perceive the surrounding environment primarily through vision. As insects are in mid-flight, visual cues enable them to generate an optic flow field. Optic flow is the apparent movement of texture in the visual field relative to the insect's velocity. A common insect flight behavior is collision avoidance. Areas in the environment with high optic flow fields correspond to imminent collisions [3]. Insects avoid collisions by turning away from these areas.

Capturing such sensing techniques into a packaged lightweight sensor is possible through mixed-mode and mixed-signal VLSI techniques [6] [1]. Centeye has developed the one-dimensional *Ladybug* optic flow microsensors based on such techniques. These sensors are inspired by the general optic flow model of animal visual systems. A lens focuses an image of the environment onto a focal plane chip, which contains photoreceptor circuits and other circuits necessary to compute optic flow. Low level feature detectors respond to different spatial or temporal entities in the environment, such as edges, spots, or corners. The elementary motion detector (EMD) is the most basic structure or entity that senses visual motion, though its output may not be in a form easily used. Fusion circuitry fuses information from the EMDs to reduce errors, increase robustness, and produces a meaningful representation of the optic flow for specific applications.

The resulting sensor, including optics, imaging, processing, and I/O weighs 4.8 grams. This sensor grabs frames up to 1.4 *kHz*, measures optic flow up to 20 *rad/s* (4 bit output), and functions even when texture contrast is just several percent. Integrating insect flight patterns with Centeye's hardware, we were able to demonstrate collision avoidance for both fixed-wing aircraft and blimps (see Figures 6 and 7) [4]. Although Centeye's optic flow sensors are not yet available commercially, Agilent Technologies' ADNS-2051 optical sensor can be utilized to achieve similar results.

3.2 Computer Vision

In addition to providing situational awareness, on-board cameras can be used for navigation. Implementing computer vision algorithms, such as referencing the horizon for flight stabilization [12], on minia-

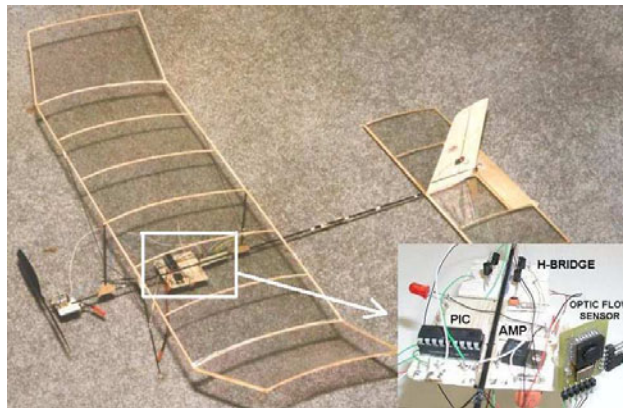

Figure 7: Fixed-wing aircraft equipped with optic flow sensor suite.

ture UAVs, however, requires small, lightweight image acquisition devices. RC Toys' *Eyecam*² is about as small as a US quarter coin, weighs just 15 *grams*, and transmits color video on a 2.4 GHz frequency. The output from the wireless receiver is composite video, which can be digitized with Hauppauge's USB-Live³ and fed into a PC for processing. Translation and rotation commands can then be sent to an on-board receiver through the PC-to-RC circuit.

The above hardware setup was used to demonstrate line following. Figure 8 shows a series of photos depicting the blimp position (top) and screenshots of the GUI (bottom) as the blimp visually servos the 20-foot line. To make the experiment less trivial, the blimp was initially oriented at an angle of 30 degrees relative to the line. It can be seen from the images that the blimp experienced an oscillatory effect in terms of rotation about the vertical axis. This was a result of the yawing motor not being able to instantly overcome the blimp's rotational inertia.

The video image was first thresholded to segment the line from the background information. Then, the orientation of the line was estimated by finding the centroid of the top and bottom halves of the image. Finally, a proportional-derivative controller, with gains $k_p = 4$ and $k_d = 1.5$, was implemented to force the orientation of the line to be vertical (i.e. error=0). The output of the PD controller determined the voltage going to the yawing motor of the blimp (located at the rear).

Video in outdoor open areas is usually transmitted ef-

²<http://www.rctoys.com/eyecam.php>

³<http://www.hauppauge.com>

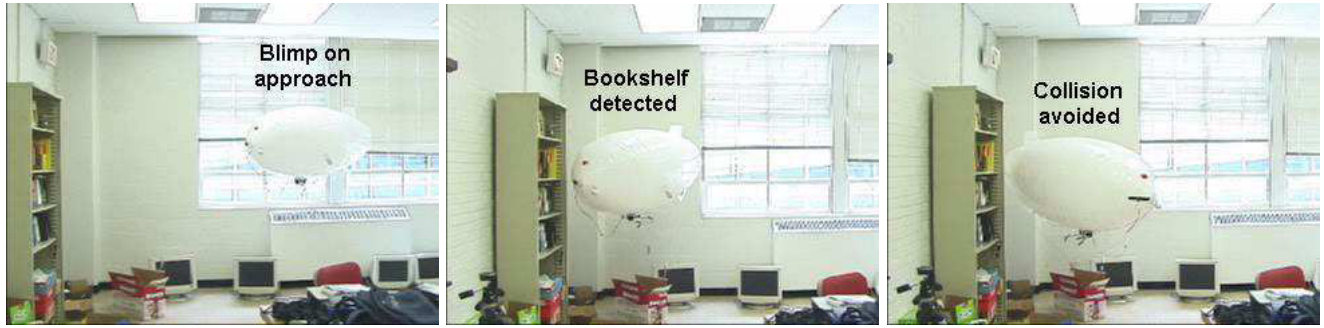

Figure 6: Optic flow is used to sense when an obstacle is within close proximity of the blimp. The blimp avoids the collision by giving full throttle to the yawing motor.

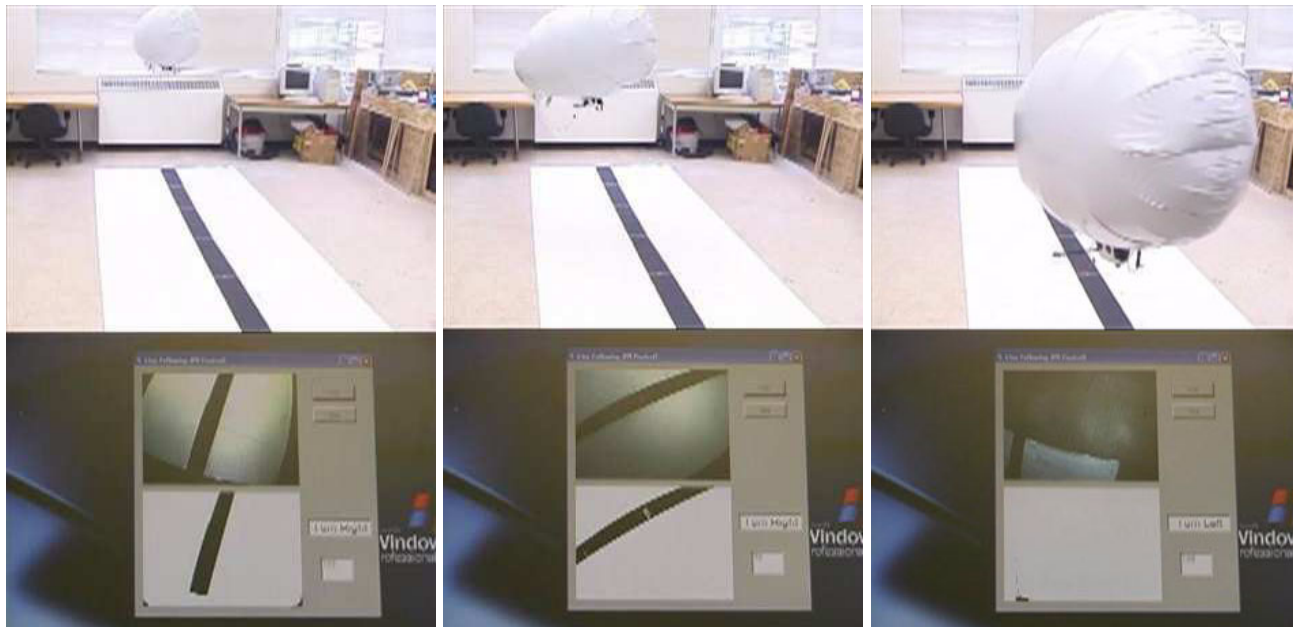

Figure 8: A wireless camera is coupled with a computer vision algorithm to achieve line following.

ficiently, thus, reducing image noise. However, wireless communications in near-Earth environments are degraded. This makes image processing techniques much more difficult to implement. With heightened interest in miniature UAVs capable of flying through forests, caves, and tunnels, there is a need to highlight other key challenges which can potentially deteriorate sensors and control algorithms. An aerial robot competition could help to identify some of the unknown threats in these areas.

4 Aerial Robot Competition

In May 2005, Drexel University organized the first indoor aerial robot competition. The competition

serves to highlight key challenges facing small unmanned aircraft when carrying out missions in near-Earth environments. The inaugural competition, featuring undergraduate teams from Drexel University and Swarthmore College (advised by Professor Bruce Maxwell), focused on both autonomous navigation and target identification in urban-like areas⁴.

4.1 Autonomous Collision Avoidance

One of the major challenges of autonomous flight in near-Earth environments is the limited availability of GPS. The competition mimicked this by hosting the

⁴Thanks to Professors Hong Zhang and Rungun Nathan from Rowan and Villanova Universities, respectively, for judging the competition



Figure 9: Swarthmore College’s blimp following the collision-free path.

competition indoors. The autonomous collision avoidance section utilized a 90 x 20 *foot* space populated with obstacles such as telephone poles and wire, urban structures, trees, etc (see Figure 9). While these obstacles were symbolic of an outdoor setting, hosting the competition indoors prevents the use of GPS for future competitions. The obstacles were overlaid on a white cloth, and a black line ran through the course to denote a collision-free path. Teams had to implement a line following algorithm in real-time that was invariant to changing lighting conditions (i.e. a glass roof enable sun to light up portions of the course) and noise from indoor video transmission. Towards the end of the course, robots were met with a low-speed fan to simulate wind disturbances. Points were awarded based on how far through the course robots were able to travel.

4.2 Teleoperated Target Identification

The other section of the competition consisted of several mock victims spaced out in a 90 x 50 *foot* area. These victims were positioned in a non-conscious manner, perhaps as a result of a chemical or biological agent released through the ventilation system of an office building (see Figure 10). Using a wireless camera mounted on the blimp’s gondola, teams utilized teleoperated control to identify survivors and deploy markers (symbolic of radio beacons) pinpointing their locations before hazmat teams can arrive. Blimp operators were only permitted to view video images transmitted wirelessly from the blimp’s camera and could not directly view the search area. Points in this

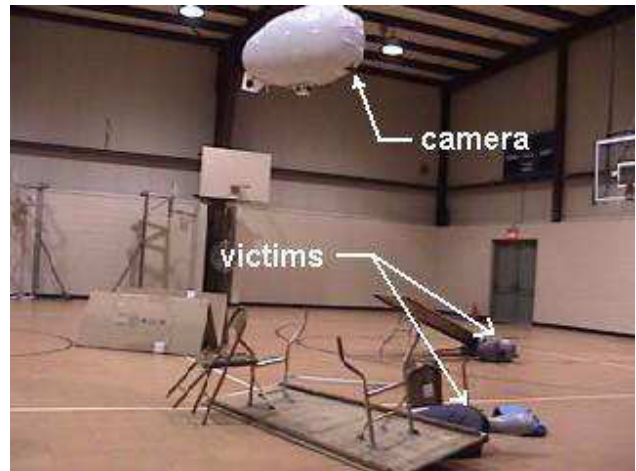

Figure 10: In the search-and-rescue portion, teams will have to locate victims by viewing images transmitted from the robot’s wireless camera.

section were awarded based on the marker proximity to survivors.

4.3 Results

The difficulty of the line following section was evident after practice runs for each team. To compensate for this, each team was allotted two restarts (i.e. the blimp can be placed back in the position it last lost the line). With the incorporation of this rule, both teams were able to follow the line until reaching the fan area, a distance of 75 feet. Once confronted with low speed wind currents, each team’s blimp was immediately blown off course, unable to demonstrate gust stabilization. The target identification task also proved to be difficult. Teams were only able to locate and mark 1 to 4 victims out of a possible 8. In addition to the scores accumulated in the collision avoidance and target identification sections, each team was also judged on the design of both the flight system and the marker deployment mechanism. The overall winner of the 2005 competition was Drexel University.

The key challenges identified in the inaugural competition were found mostly in the line following section. For example, sunlight shined sporadically on the course resulting in large gradients which effected the efficiency of the computer vision algorithms. Also, wireless video transmission indoors is diminished, but still usable at short distances (i.e. \leq 100 feet). Furthermore, stabilizing an aerial robot in the presence of wind gusts is still a prevalent challenge.

In the teleoperated portion of the competition, teams found it difficult to interpret the raw video transmitted from the blimp's wireless camera. A *bird's eye* view is oftentimes unfamiliar to the operator and may require some image processing (e.g. object recognition) techniques to identify victims, tables, chairs, etc.

5 Conclusions

The design of a sensor suite for small unmanned aircraft varies greatly from the sensor suites utilized on traditional UAVs. Flying below tree tops or in and around urban structures prevents the use of GPS. Furthermore, devices such as inertial measurement units and gyros often strain the payload capacities of small, lightweight aircraft. Design then focuses on achieving fundamental autonomous tasks such as altitude control and obstacle avoidance using the smallest packages possible. Advancements in sensor suites tend to define the level of sophistication of the UAV. However, even the most highly-developed control system will fail when presented with unforeseen obstacles. Telephone wires, for example, are extremely thin, but could easily be fatal to a UAV. Such near-Earth environment impediments must be properly identified and factored into control system design. The annual indoor aerial robot competition is fashioned to encourage innovation in this field.

References

- [1] Barrows, G., "Mixed-Mode VLSI Optic Flow Sensors for Micro Air Vehicles", *Ph.D. Dissertation*, University of Maryland, College Park, MD, Dec. 1999.
- [2] Blitch, J., "World Trade Center Search-and-Rescue Robots", Plenary Session *IEEE Int Conf Robotics and Automation*, Washington D.C., May 2002.
- [3] Gibson, J.J., *The Ecological Approach to Visual Perception*, Houghton Mifflin, 1950.
- [4] Green, W.E., Oh, P.Y., Barrows, G., "Flying Insect Inspired Vision for Autonomous Aerial Robot Maneuvers in Near-Earth Environments", *IEEE International Conference of Robotics and Automation*, pp. 2347-2352, New Orleans, LA, April 2004.
- [5] Green, W.E., Oh, P.Y., "An Aerial Robot Prototype for Situational Awareness in Closed Quarters", *IEEE/RSJ Int Conf on Intelligent Robots and Systems*, pp. 61-66, Las Vegas, NV, Oct. 2003.
- [6] Harrison, R., Koch, C., "An analog VLSI implementation of a visual interneuron: enhanced sensory processing through biophysical modeling", *International Journal of Neural Systems*, 9: 391-395, 1999
- [7] Hamel, T.; Mahony, R., Chriette, A., "Visual Servo Trajectory Tracking for a Four Rotor VTOL Aerial Vehicle", *IEEE International Conference on Robotics and Automation (ICRA)*, Washington, D.C., pp. 2781-2786, 2002.
- [8] Murphy, R., et al, "Mobility and sensing demands in USAR", *IEEE Industrial Electronics Conference (IECON)*, V1, pp. 138-142, 2000.
- [9] Choi, H., Sturdza, P., Murray, R.M., "Design and Construction of a Small Ducted Fan Engine for Non-linear Control Experiments", *Proc. American Control Conf.*, Baltimore MD, pp. 2618-2622, June 1994.
- [10] Nicoud, J.D., Zufferey, J.C., "Toward Indoor Flying Robots", *IEEE/RSJ Int Conf on Robots and Systems*, Lausanne, pp. 787-792, October 2002.
- [11] Oh, P.Y., Green, W.E., "Closed Quarter Aerial Robot Prototype to Fly In and Around Buildings", *Int. Conference on Computer, Communication and Control Technologies*, Vol. 5, pp. 302-307, Orlando, FL, July 2003.
- [12] Pipitone, F., Kamgar-Parsi, B., Hartley, R., "Three Dimensional Computer Vision for Micro Air Vehicles", *Proc. SPIE 15th Aerosense Symposium*, Conf. 4363, Enhanced and Synthetic Vision 2001, Orlando Florida, April 2001.
- [13] Sevcik, K., Oh, P. "PC to RC Interface", *Servo Magazine*, July 2004
- [14] Zhang, H., Ostrowski, J.P., "Visual Servoing With Dynamics: Control of an Unmanned Blimp", *IEEE International Conference on Robotics and Automation (ICRA)*, Detroit, pp. 618-623, 1999.